

Detection of Ischemia using MATLAB

D. Kavya, M.J. Vidya and K.V. Padmaja

Abstract--- Ischemia is a restriction in the blood supply to tissues causing a shortage of oxygen and glucose needed for cellular metabolism. It is considered to be the major complication of the cardiac function, and a prime cause for the occurrence of cardiac infarction and dangerous cardiac arrhythmias. Several mathematical transforms have been applied to ECG for ischemia detection such as Discrete cosine transform(DCT), discrete fourier transform(DFT), discrete fourier transform(DFT) or RMS different series. Wavelet transforms shows good learning and detection capabilities which is an efficient tool to deal with uncertainties. Algorithm is presented in order to detect ischemia diseases in Electrocardiogram (ECG) signals. The techniques used comprise of signal preprocessing, feature extraction and classifier for signal classification.

Keywords--- Ischemia, Wavelet Transform, Base Line Wandering, Feature Extraction, Classifier

I. INTRODUCTION

ISCHEMIC Disease is the leading cause of death. It is the restriction in the blood supply to the tissues. Blood flow can be blocked by a clot or constriction of an artery. It can occur due to thickening of artery wall. It is usually detected in the surface ECG from the repolarization period. The main characteristic of ischemia at the cellular level is the depolarization of the cellular resting membrane potential. This causes a potential difference between the normal and ischemic tissue which, in turn, causes the flow of an injury current. This injury current is manifested in the electrocardiogram (ECG) by an ST depression or elevation, depending on the anatomical position of the heart. The decrease in blood flow reduces the heart's oxygen supply. Myocardial ischemia, also called cardiac ischemia, can damage your heart muscle, reducing its ability to pump efficiently. A sudden, severe blockage of a coronary artery may lead to a heart attack [1]. Myocardial ischemia may also cause serious abnormal heart rhythms. Treatment for myocardial ischemia is directed at improving blood flow to the heart muscle and may include medications, a procedure to open blocked arteries or coronary artery bypass surgery. Pain is a common symptom associated with ischemia, but does not always occur. Brain ischemia can cause cognitive, sensory or motor problems. Treatment of ischemia depends on the cause,

but generally is aimed at restoring blood flow and reducing further tissue injury and death.

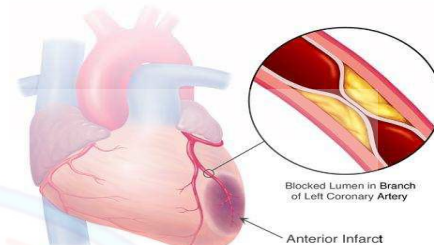

Fig.1: Ischemia[2]

II. PHYSIOLOGICAL BACKGROUND

Anatomy of heart- The heart is responsible for pumping blood to the organs and cells throughout the body to provide them with the nutrients and oxygen needed for survival. The heart is comprised of four chambers. The upper left and upper right chambers are called atria, while the lower left and lower right chambers are called ventricles. The chambers are separated by a muscle called the septum, and there are multiple valves to connect the various chambers to each other.

Electrocardiogram- The ECG scan is essentially a periodic waveform. One cycle of the blood transfer process from heart to the arteries is represented by the one period of the ECG waveform. This part of the waveform is generated by an electrical impulse originated at sino-atrial node in the right atrium of the heart. The impulses causes contraction of the atria which forces the blood in each atrium to squeeze into its corresponding ventricle [3]. The resulting signal is called the P wave. The atrioventricular node delays the excitation impulse until the blood transfers from atria to the ventricles is completed, resulting in PR interval of the ECG waveform. The excitation impulse then causes contraction of the ventricles which squeezes blood into the arteries. This generates the QRS part of the ECG waveform. During this phase the atria are relaxed and filled with blood. The T wave of the waveform represents the relaxation of ventricles. The complete process is repeated periodically, generating the ECG trace.

D. Kavya, M. Tech, 2nd Yr., Department of Instrumentation Technology, R V College of Engineering, Bangalore.

M.J. Vidya, Assistant Professor, Department of Instrumentation Technology, R.V College of Engineering, Bangalore.

K.V. Padmaja, Professor and Associate Dean, Department of Instrumentation Technology, R.V College of Engineering, Bangalore.

III. BLOCK DIAGRAM

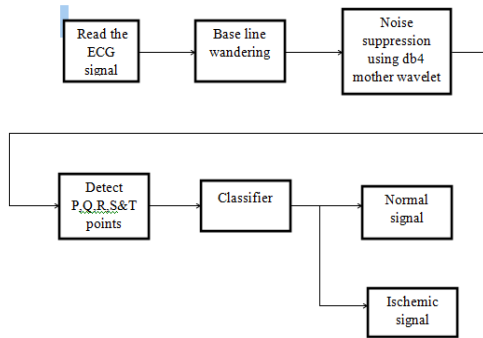

Fig. 2: Block Diagram for the Detection of Ischemia

A. Baseline Wandering and Noise Suppression

ECG recording contain significant amount of noise and preprocessing of the ECG recording is performed to achieve noise removal the recorded signal is corrupted by different types of noise and interference, originated by another physiological process of the body[5]. Wavelet analysis is performed using db4 mother wavelet. Approximation coefficients are computed at level N using wavelet decomposition structure.

• Wavelet and Window Method

A wavelet is simply a small wave which has energy concentrated in time to give a tool for the analysis of transient, non-stationary or time-varying phenomena such as a wave shown in figure 3.

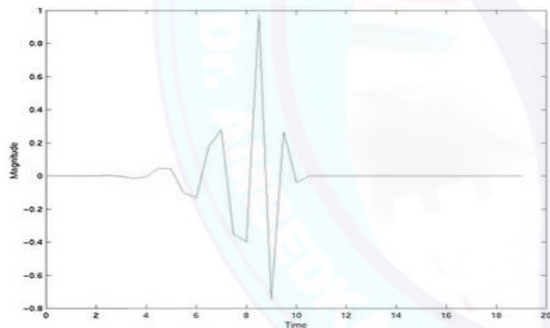

Fig. 3: Wavelet Function [6]

A signal as the function of $f(t)$ shown in Fig.3 can often be better analyzed and expressed as a linear decomposition of the sums: products of the coefficient and function. In the Fourier series, one uses sine and cosine functions as orthogonal basis functions[7]. But in the wavelet expansion, the two-parameter system is constructed such that one has a double sum and the coefficients with two indices.

Wavelet transforms have been one of the important signal processing developments in the cast decade, especially for the such as time- frequency analysis, data compression, segmentation and vision. During the past decade several efficient implementations of wavelet transforms have been derived. Wavelet analysis is performed using a prototype function called a wavelet.

Wavelets are the functions derived over a finite interval and having an average value of zero. The basic idea of

wavelet transform is to represent any arbitrary function $f(t)$ as a superposition of a set of such wavelets as basis functions.

Wavelet analysis consists of two process:

- Wavelet Decomposition
- Wavelet Reconstruction

• Wavelet Decomposition

Wavelet decomposition can be regarded as projection of the signal on the set of wavelet basis vectors. Each wavelet coefficient can be computed as the dot product of the signal with the corresponding basis vector[8]. one signal is broken down into many lower-resolution components.

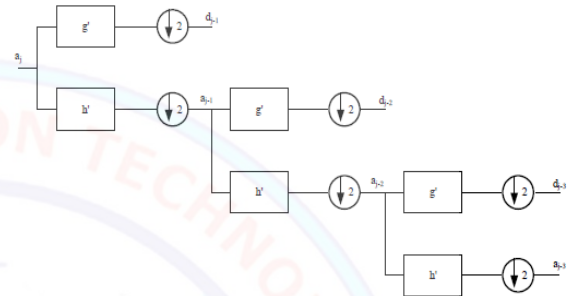

Fig. 4: Wavelet Decomposition [6]

• Wavelet Reconstruction

The signals are assembled back into the original signal. This process will have more accurate analysis of wavelet. Basically, the reconstruction is the reverse process of decomposition. The approximation and detail coefficients at every level are upsampled by two, passed through the low pass and high pass synthesis filters and then added [9]. This process is continued through the same number of levels as in the decomposition process to obtain and H the original signal.

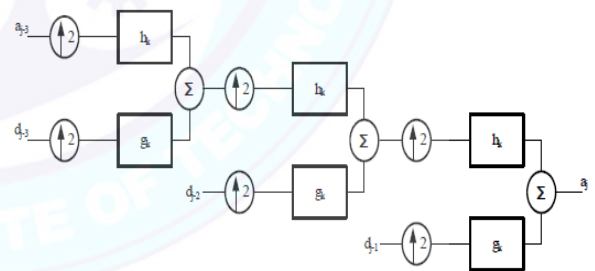

Fig. 5: Wavelet Reconstruction[6]

In figure 5, 'h' is low-pass filter, 'g' is high-pass filter, '↑2' is up sampling.

B. Feature Extraction and Selection

ECG measurement is now used both for monitoring and diagnosis as a detection method of vast range of anomalies. The most important values to be measured are regularity of the signal, the distances between characteristic points and interferences in the shape of single heartbeat. R peak location is detected by keeping 60% of the signal as threshold. Q, S

and T points is detected with reference to R locations. ST deviation plays an important role in ischemia detection.

IV. IMPLEMENTATION

Algorithm for the Detection of Ischemia

Step 1: Read the ECG signal

Step 2: Detect the QRS complex waveform.

Step 3: Perform the wavelet analysis.

Step 4: Compute the approximation coefficients using wavelet decomposition.

Step 5: Detect R peak location in the signal keeping 60% of the signal as threshold.

Step6: Detect Q point by finding the minimum value in the range Rloc-50 to Rloc-10.

Step 7: Detect S point by finding the minimum value in the range Rloc+5 to Rloc+50.

Step 8: Detect T point by finding the maximum value in the range Rloc+25 to Rloc+100.

Step 9: Calculate ST deviation using the following steps:

$$PR \text{ point } (i,j) = \text{ceil}(R \text{ loc}(i,j) - (\text{SOFF}(i,j) - \text{QON}(i,j))/2);$$

$$ST \text{ point } (i,j) = \text{ceil}(T \text{ loc}(i,j) - (\text{TOFF}(i,j) - \text{TON}(i,j))/2);$$

$$ST \text{ Deviation}(i,j) = \text{abs}(x(\text{PR point}(i,j),i) - x(\text{STpoint}(i,j),i));$$

Step10: Find $X = |STDeviation|/100$. If $X > 1$, ischemia is detected.

Flowchart for the Detection of Ischemia

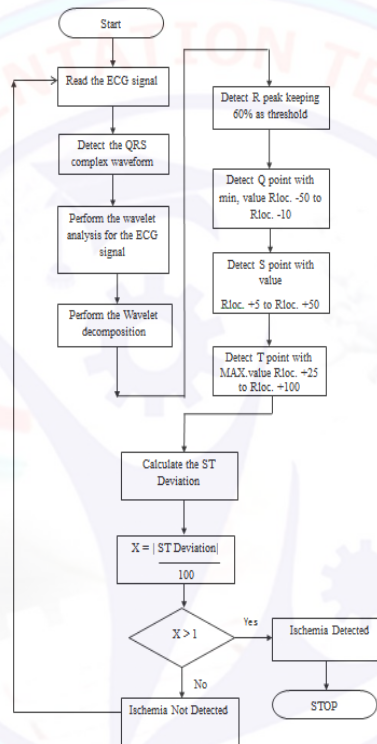

Fig. 6: Flowchart for the Detection of Ischemia

V. RESULTS

1. Normal ECG Signal

ST segment deviation = 0.1488

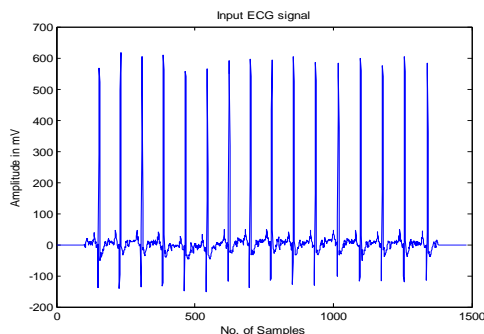

Fig.7: Normal ECG Signal

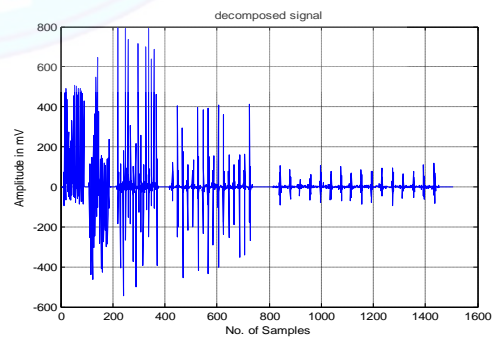

Fig. 8: Decomposed Signal

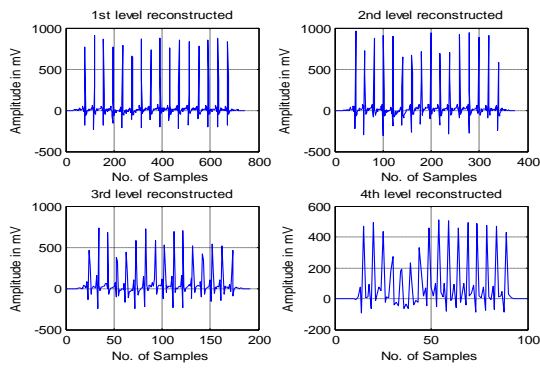

Fig. 9: Reconstructed Signal

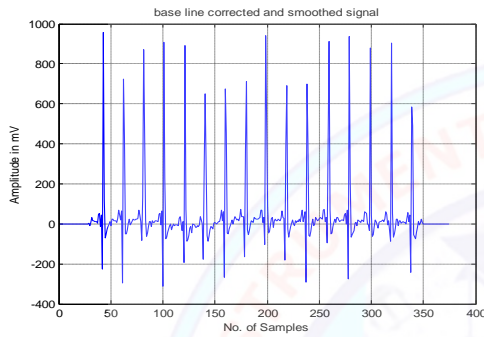

Fig. 10: Baseline Corrected and Smoothed Signal

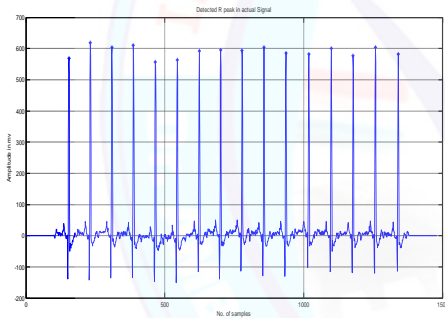

Fig. 11: Detected R Peak in Actual Signal

2. Ischemic ECG Signal

ST segment deviation=1.1875

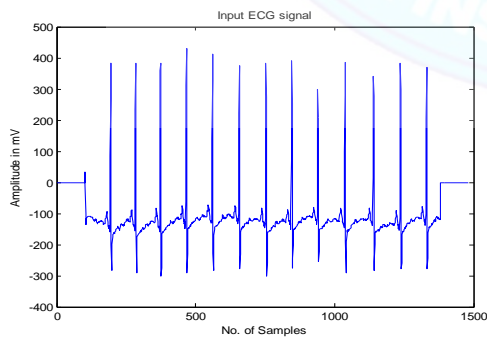

Fig. 12: Ischemic Signal

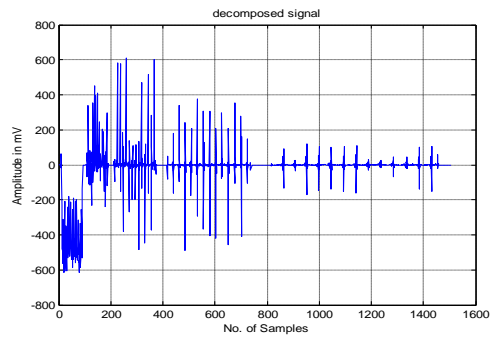

Fig. 13: Decomposed Signal

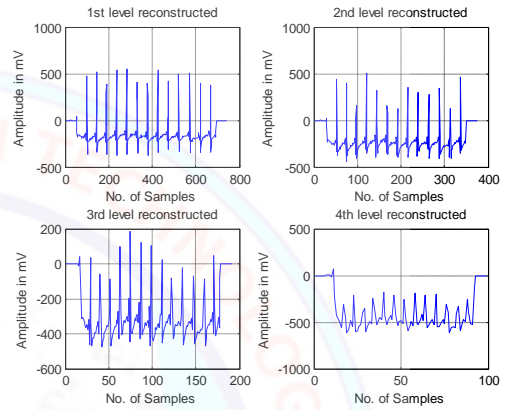

Fig. 14: Reconstructed Signal

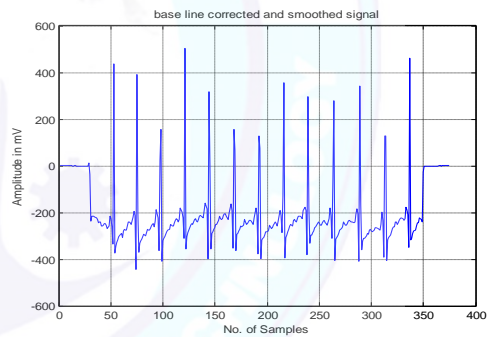

Fig. 15: Baseline Corrected and Smoothed Signal

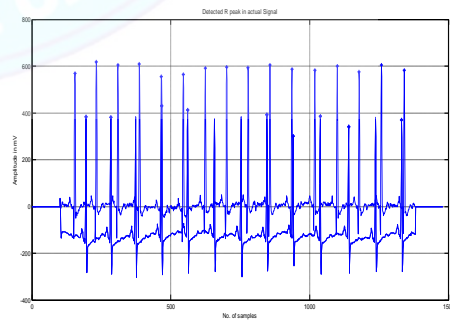

Fig. 16: Detected R Peak in Actual Signal

VI. CONCLUSION

The results shows that wavelet method can remove the noise in the signal effectively. Wavelet transform can analyze noise signal in time domain and frequency domain. It is suitable for transient signal detection. ST segment plays an important role in the detection of ischemia. ST deviation is calculated and the ischemia status is detected.

REFERENCES

- [1] Li Sun, Yanping Lu, Member, IEEE, Kaitao Yang, Shaozi Li, *ECG Analysis Using Multiple Instance Learning for Myocardial Infarction Detection*, July 2012
- [2] Nicos Maglaveras, Member, IEEE, Telemachos Stamkopoulos, Costas Pappas, An adaptive Backpropagation Neural Network for Real-Time Ischemia Episodes Detection, IEEE transactions on biomedical engineering, Vol.45, no.7, July 2008
- [3] [3]A.Emam,H.Tonekabonipour,M.Teshnelab,M.AliyariShoorehdeli, Mechatronics Department, Qazvin Islamic Azad University, Qazvin, Iran, Ischemia prediction using ANFIS, Advanced Process Automation and Control, 2010
- [4] Lacramioara Dranca, Alfredo Goñi, Arantza Illaramendi, Using decision trees for real-time ischemia detection, 19th IEEE Symposium on Computer-Based Medical Systems (CBMS'06), 2006.
- [5] M.Faezipour et. al. A Patient Adaptive Profiling Scheme for ECG beat classification, IEEE Trans. On Information Technology in Biomedicine, Vol. 14(5):1153-1165, Sep 2010
- [6] M.K. Islam, A.N.M.M.Haque, G.Tangim, T.Ahammad, and M.R.H.Khondokar, Member, IACSIT, *Study and Analysis of ECG Signal Using MATLAB & LABVIEW as Effective Tools*, International journal of Computer and Electrical engineering, Vol.4, no.3, June 2012
- [7] Zhang zhen, RU Yi, *Research of the signal De-noising in Life Detection Based on Wavelet Transform*, Third International Symposium on Intelligent Information Technology Application, 2009
- [8] Amit kumar manocha, Mandeep singh, *An Overview of Ischemia detection techniques*, International Journal of Scientific and Engineering Research, Volume 2, Issue 11, November 2011
- [9] N.C Griswold, Somit Shah Mathur, Mark Yeary, Ronald G. Spencer, *Wavelet Decomposition or Reconstruction of images via direct products*, Journal of Electric Imaging 9(1), 61-71 (January 2000).
- [10] Mikhled Alfaouri and Khaled Daqrouq, ECG signal Denoising from Wavelet Transform Thresholding, American Journal of Applied Sciences 5(3), 276-281, 2008
- [11] Zhao Hong-tu, Yan Jing, College of Computer Science & Technology, *The Wavelet Decomposition and Reconstruction Based on the MATLAB*, Proceedings of the Third International Symposium on Electronic Commerce and Security Workshop (ISECS '10), pp. 143-145, July 2010
- [12] Adam Josko, Remigiusz J. Rak, *Effective Simulation of Signals for Testing ECG Analyzer*, IEEE transactions on Instrumentation and Measurement, Vol. 54, No. 3, June 2005
- [13] Esther Pueyo, Leif Sömmö, Senior Member, IEEE, and Pablo Laguna, *QRS Slopes for detection and characterization of Myocardial Ischemia*, IEEE transactions on biomedical Engineering, Vol. 55, No. 2, February 2008
- [14] Raghu Vishnubhotla and Sen M Kuo, Development of Ambulatory Ischemia Detection Devices, 2010.
- [15] Vijayalakshmi Ahanathapillai, John J Soraghan, Myocardial Ischemia Detection Algorithm (MIDA): Automated Echocardiography Sequence Analysis for diagnosis of Heart muscle Damage, Computing in Cardiology, 2010.
- [16] L. S. Geddes and W. E. Cascio, H. A. Fozzard et al., Eds. New York: Raven, *Effects of acute ischemia on cardiac electrophysiology in the Heart and Cardiovascular System*, vol. 2, pp. 2021-2054, 1991
- [17] M. Sejersten, G. S. Wagner, O. Pahlm, J. W. Warren, C. L. Feldman, and B. M. Horáček, *Detection of acute ischemia from the EASI-derived 12-lead electrocardiogram and from the 12-lead electrocardiogram acquired in clinical practice*, vol. 40, no. 2, pp. 120-126, 2007.